



# PROMATION

*Innovative Solutions for Electronics Mfg.*



## BARE BOARD LOADING – Vacuum Style

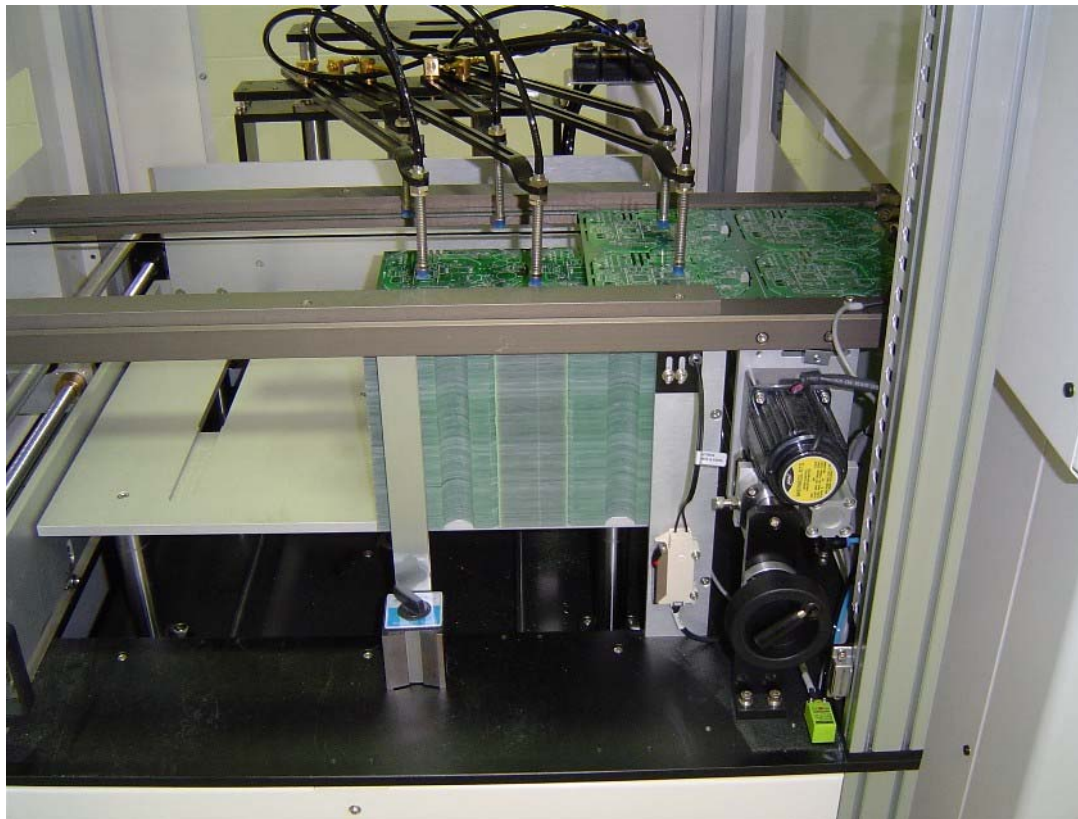

Can hold stacks of PCBs (up to 160 pcs.)



# PROMATION

*Innovative Solutions for Electronics Mfg.*



## BARE BOARD LOADING – De-Stacker



For PCBs with many holes that can not be held by vacuum, or for those customers who just prefer a mechanical de-stacking style system, The De Stacker provides a reliable means to transfer PCBs to the line.

Our multi-bar separation process allows for two incremental drop steps to assure proper placement of the PCB onto the rails.

PASS through is also standard.



# PROMATION

*Innovative Solutions for Electronics Mfg.*



## PCB DEBRIS REMOVER

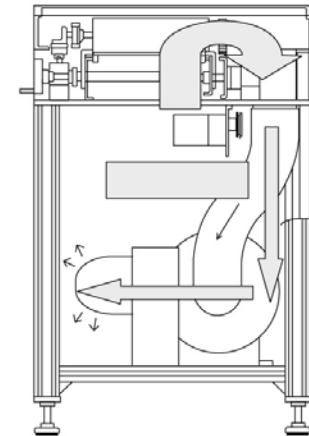

Gently sweeps and vacuums  
PCBs prior to screen printing.

Has internal vacuum system with filters and optional  
ionizer bar